

B & K

SIMPLY BETTER!

B&K Components, Ltd.

ST55.2

OWNER'S MANUAL

B&K Components, Ltd., 2100 Old Union Road, Buffalo New York 14227-2725
Phone 1-800-543-5252 or (716) 656-0026, **Fax** (716) 656-1291
E-mail: info@bkcomp.com **Web:** www.bkcomp.com

TABLE OF CONTENTS

Table of Contents	iii
Safety Precautions	1
Purpose and Function.....	2
Design and Construction.....	2
Features.....	2
Rear Panel	3
Control Muting	4
Level Controls.....	5
Inputs	5
Outputs	5
Internal Bus Structure.....	6
Jumper Description	7
Mono Application (Medium Current)	7
Bridged Application (High Voltage).....	8
System Installation	9
Making the Connection	9
Troubleshooting	10
Care and Cleaning	10
Specifications	11
Limited Warranty	12
Returning Equipment.....	12
WWW.BKCOMP.COM	13

SAFETY PRECAUTIONS



PLEASE READ BEFORE INSTALLING

WARNING: to prevent fire or shock hazard, do not expose this unit to rain or moisture. Care should be taken to prevent objects or liquid from entering the enclosure. Never handle the power cord with wet hands.

- The lightning flash with arrowhead, within an equilateral triangle, is intended to alert the user of the presence of uninsulated “dangerous voltage” within the product’s enclosure that may constitute a risk of electric shock to you.
- The exclamation point within an equilateral triangle is intended to alert the user of the presence of important operating and maintenance (servicing) instructions in the literature accompanying the unit.
- Caution: To prevent the risk of electric shock, do not remove cover. No user-serviceable *parts inside*. *Refer servicing to qualified service personnel.*
- Unplug the amplifier from the AC outlet when plugging in or unplugging cables, when left unused for an extended period of time, moving the amplifier, or when you suspect lightning in your area.
- Prevent damage to the power cord. Do not bend, pull, place objects on, alter, etc. Replace the power cord if it becomes damaged. Always grasp the plug on the power cord when plugging in or unplugging the amplifier from the AC outlet.
- Your system may produce sound levels capable of causing permanent hearing loss. Do not operate for extended periods of time at high volume levels.
- Make sure the amplifier is placed on a level surface.
- The amplifier is equipped with raised feet to provide ventilation, reduce acoustic feedback, and provide protection against scratching the surface the unit is resting on. We advise against removing or altering feet.
- Do not stack anything on top of the amplifier (processor, source, etc.) Leave a minimum of 2” clearance from the top of the amplifier to the next shelf (or component) to insure proper ventilation.
- The amplifier should be located away from other sources that may be sensitive to heat.
- Do not perform any internal modifications to the amplifier.
- Always connect the amplifier’s power cord to an unswitched AC outlet for normal operation.
- If young children are present, adult supervision should be provided until the children are capable of following all rules for safe operation.
- Do not plug the amplifier’s power cord into an outlet with an unreasonable number of other devices. Be careful if using extension cords and ensure the total power used by all devices does not exceed the power rating (watts/amperes) of the extension cord. Excessive loads may cause the insulation on the cord to heat and possibly melt.
- Mistaking **CONTROL OUTPUT** or **CONTROL INPUT** connectors for audio/video inputs or outputs may damage your amplifier or other components.
- Damage can occur to your speakers if the power rating of each individual driver is exceeded by the amplifier. Ensure that all the drivers in your system are capable of handling not only the average power being delivered by the amplifiers, but also the peak power that is likely to be generated during strong passages. If you are unsure of your speaker’s power rating, contact the speaker manufacturer or the dealer where you purchased them.
- The amplifier should be serviced by qualified personnel when:
 - A. The amplifier is not functioning properly.
 - B. Objects have entered the chassis.
 - C. The amplifier was exposed to rain or other type of moisture.
 - D. The amplifier was dropped, or the chassis is damaged

PURPOSE AND FUNCTION

The ST55.2 is a compact, very efficient, two channel power amplifier. It is designed for use in all types of audio or audio/video systems. The term versatile is almost adequate to describe the variance of operational modes the ST55.2 is capable of providing. This is all accomplished through the simple placement of internal jumpers and the paralleling or bridging of its outputs and/or linking multiple ST55.2's.

Here is a listing for some of the many tasks it can be set up to perform:

- The most obvious function for the ST55.2 is to take 2 separate audio inputs, such as a stereo pair, and provide 2 separate amplified outputs. Your ST55.2 has arrived set up in this configuration.
- With the inputs buffered, a line output (OUT BUS) may be taken from the L BUS, R BUS, or L+R BUS and sent on to another amplifier. This allows for linking of multiple amplifiers.
- Continuing its versatility, the ST55.2 may be used mono to provide one, medium current channel in order to drive a speaker requiring more power.
- As a result of the ST55.2's unique bus system, the input to the left channel may be inverted thereby allowing the possibility of creating a single high voltage (bridged) channel from one source, through the left bus.

DESIGN AND CONSTRUCTION

The ST55.2 utilizes high quality electronic circuitry to achieve an environment wherein a detailed, transparent, and highly musical sound can be realized. The high quality complement of parts, include state-of-the-art solid-state devices, 1% metal film resistors, computer grade electrolytic power supply capacitors, and a high capacity toroidal transformer.

FEATURES

Toroidal Transformer - Efficient high current transformer for improved dynamics.

Discrete Circuitry - More accurate and three dimensional reproduction of source material.

Limited Protection - Provides short term protection from accidental shorting of output devices and protection from thermal overload.

Gold Plated Connectors - Improve connections for better sound and minimized signal loss and degradation.

1% Metal Film Resistors - Low noise resistors for better sound and a greater degree of repeatability.

Medium Current - Ability to reproduce demanding recordings.

Computer Grade Capacitors - Large capacity computer grade electrolytic capacitors for extended low frequency control and improved dynamics.

REAR PANEL

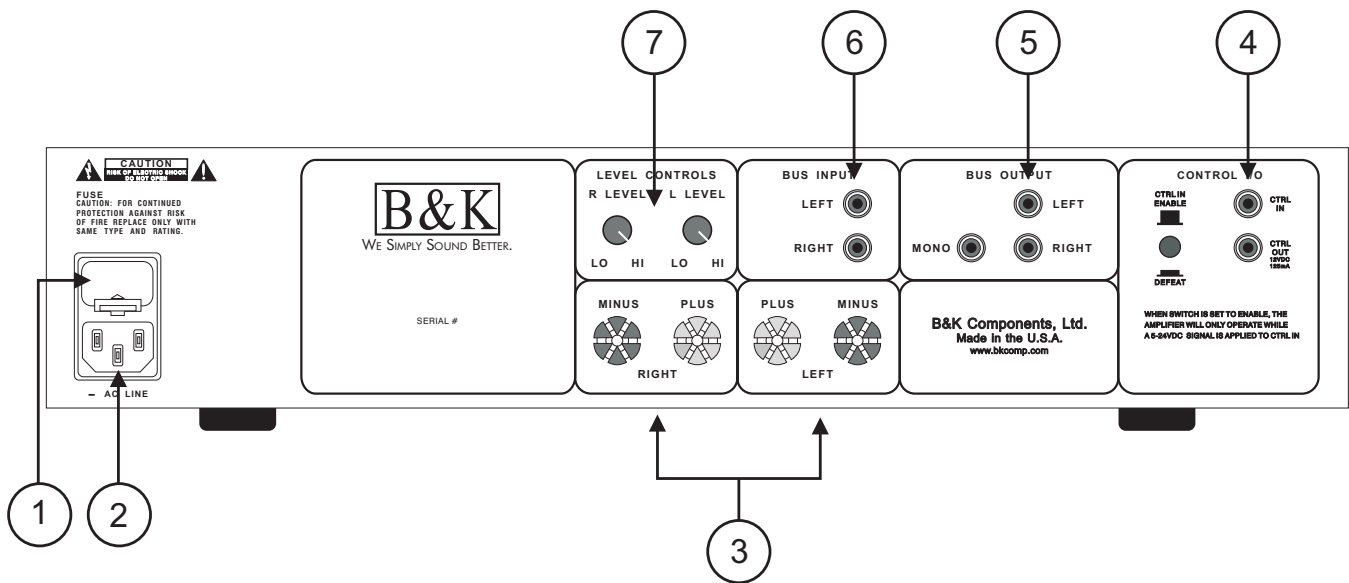

1. AC fuse holder - Holds the AC Line fuse. This fuse is an 8 Amp / 250 Volt Slow Blow fuse. Replace with same type and value fuse only.

2. AC Input receptacle - For attaching the supplied AC power cord to the amplifier.

3. Speaker outputs - For connecting the speakers to the amplifier. Explained further on page 8.

4. Amplifier control muting input/output - To provide remote switching of mute on/off of the amplifier. Explained further on page 5.

5. Line level outputs - For connecting signal to another amplifier (daisy chaining).

6. RCA inputs - For connecting signal patch cables (interconnects) from the preamplifier to the amplifier to pass signal.

7. Level controls - For adjusting the input level to the amplifier. Explained further on page 6.

CONTROL MUTING

A control is provided on each ST55.2 amplifier to allow remote switching of mute on/off. The preamplifier's control output, such as is provided with B&K series preamplifiers, can be utilized to provide a control signal to the ST55.2. If more than one amplifier is being controlled, the control signal can be extended to include each successive unit by simply running an RCA type audio cable from the CTRL OUT connector of the first amplifier to the CTRL IN connector of the next unit (commonly referred to as 'daisy chaining'). An example of how to connect two amplifiers is illustrated in the figure below.

If a source other than a B&K series preamplifier is used to control multiple amplifiers, only the control output voltage from the source is critical. It must be within the range, as indicated on the rear panel, 5-24 volts DC is required. The amplifier will provide each successive amplifier with a control voltage of 12 volts DC for reliable operation. The **amplifiers control output may be used as a source of 12 VDC @ 125 mA for other user applications as well. DO NOT POWER MOTORS WITH THIS CIRCUIT.**

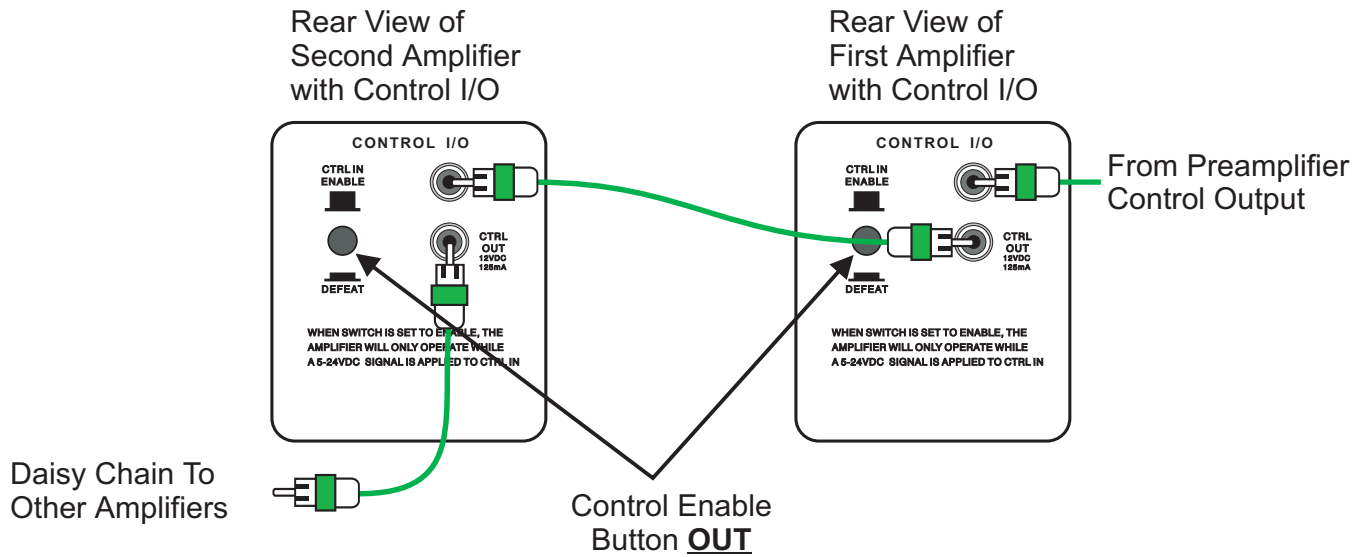

If the control function is desired, each unit in the system must remain connected at all times and the control must be enabled. To enable the control function, the CTRL ENABLE button must be out for each controllable amplifier in the system. For more information on the amplifiers output status under various control conditions, refer to the table below.

@ CTRL IN	Button position	Output status	@ CTRL OUT
Signal	OUT	Sound	Signal
Signal	IN	Sound	Signal
No Signal	OUT	Mute/Standby	No Signal
No Signal	IN	Sound	Signal

**Note: The control voltage is for muting control only. Each amplifier must be connected to its own source of AC power in order for it to operate.*

LEVEL CONTROLS

There are two level controls on the back of the amplifier. One level control for each channel. When using the level controls, first start with them turned all the way up (clockwise). Then adjust them according to your system requirements to match the sound level coming from each speaker. This is a rough adjustment for matching different driver impedances. Any fine tuning should be done by the preamplifier.

Example: When using 4 ohm and 8 ohm speakers together, the 4 ohm may sound louder than 8 ohm at a given volume level. The level controls on the amplifier are used to match the speaker's volume level. Clockwise will increase the output. Counter clockwise will decrease the output.

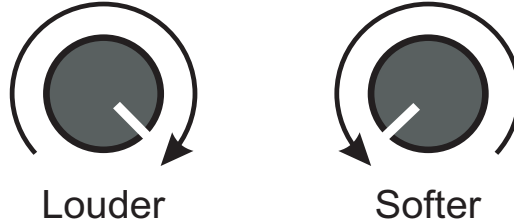

INPUTS

RCA type connectors accept line input from the preamplifier's unbalanced output connectors. There are two input connectors, one for each channel, which may be used to connect the amplifier to the preamplifier.

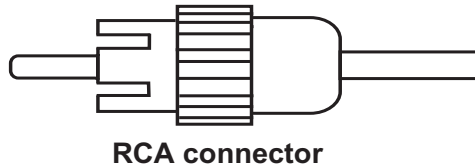

Here is a typical input setup:

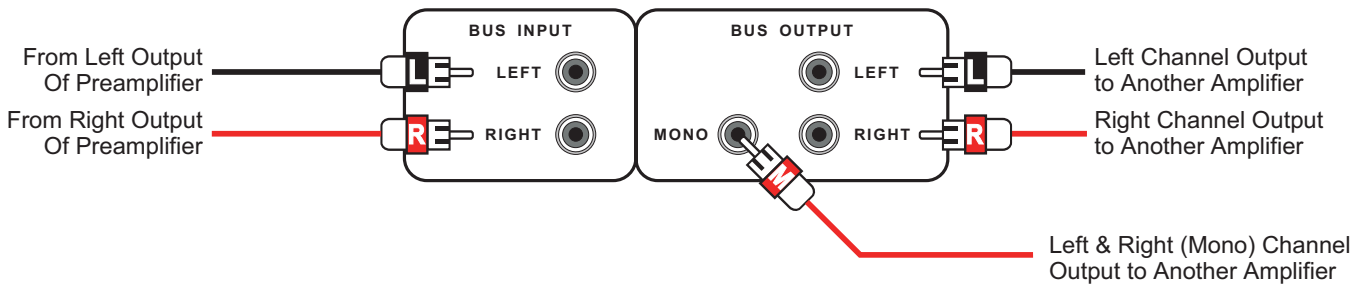

You will notice the OUT BUS connections shown above. You may use these to connect to another amplifier. The L BUS OUT carries the same signal as the L INPUT. The R BUS OUT carries the same signal as the R INPUT. The L+R BUS OUT carries the combined signal from the left and right inputs.

OUTPUTS

Five way binding posts are provided. One pair for each channel. They are designed to accept a banana-type plug or spade lug connector (shown below) and are color coded for easy identification. The red (+) post should always be connected to the speakers (+) jack. The black (-) post should always be connected to the speakers (-) jack.

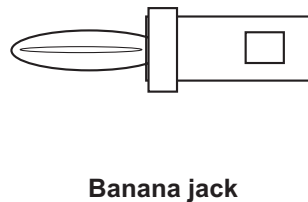

Here is a typical amplifier setup:

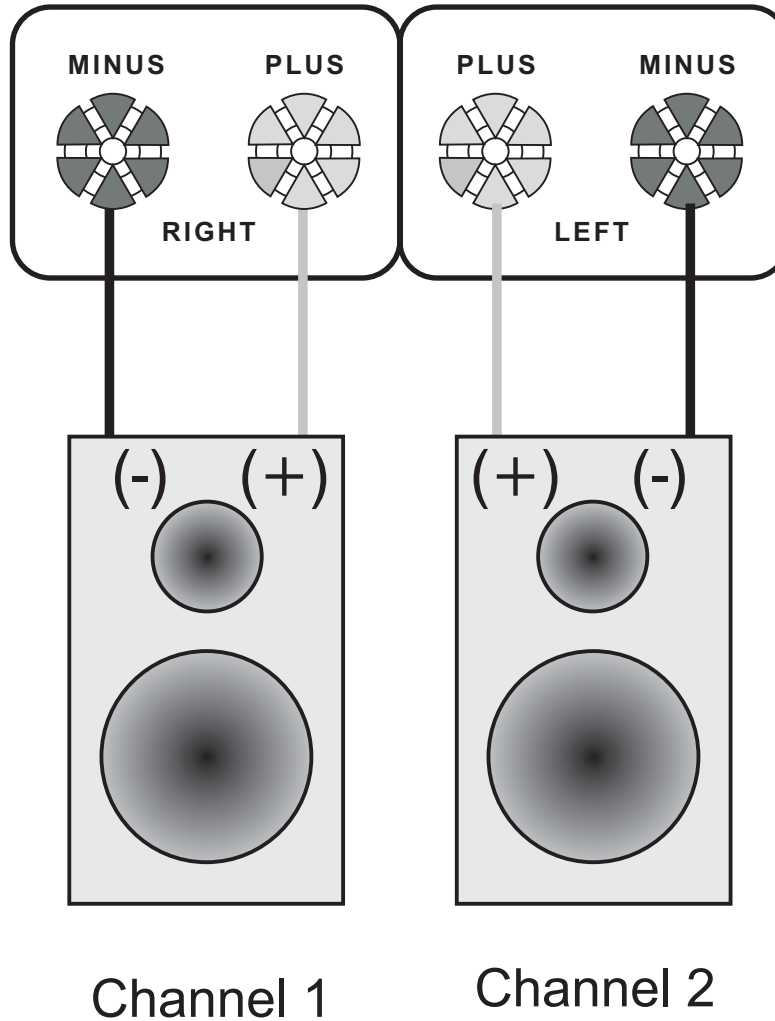

INTERNAL BUS STRUCTURE

In order to gain access to the internal bus structure, you must first remove the top cover. Turn the amplifier so the rear panel is facing your. The jumper modules may be seen on the circuit board just behind the level controls.

Below is the default setup for the ST55.2 amplifier. By arranging the jumpers allows you to configure the amplifier for different applications. If you wish to use the amplifier as a stereo (two channel) amplifier, you need not change any of the settings.

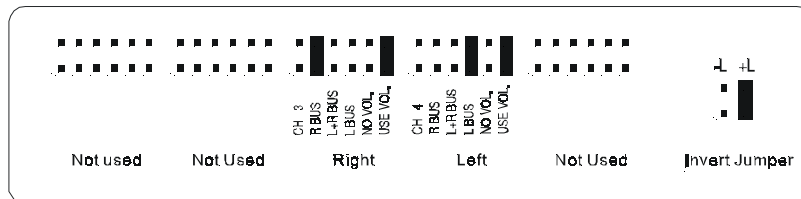

In order to reconfigure the ST55.2's channels, remove the source control group jumper from its present position (if necessary) and install it on the terminal you wish to select as the source for that channel. Make sure it has been inserted on both terminal pins of the jumper modules. To complete the configuration, the volume group jumper should be placed at either the 'USE VOL' or 'NO VOL' terminal depending on you configuration.

Note: A channel that is not being used in your configuration should have its jumper plugs installed at the default position as shown above.

JUMPER DESCRIPTION

The jumper modules are used in configuring each channel. Each jumper terminal location is conveniently labeled as to the source it can be configured to provide.

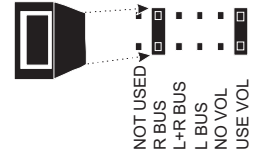

R BUS - Along with being the right channel input, it is used as the input to the right bus and the right source for the 'L+R BUS'. Because it is a BUS input, any signal input here would appear at the 'R BUS' jumper terminal for both of the ST55.2's jumper modules.

L+R BUS - Installing a jumper plug at this terminal on either of the two internal jumper modules selects the combined signal being carried by both the left and right inputs. If the left bus and right bus are being used to carry stereo right and left channels, a jumper plug installed at the 'L+R BUS' location will provide a true L+R mono output.

L BUS - Along with being the left channel input, it is used as the input to the left bus and the left source for the 'L+R BUS'. Because it is a BUS input, any signal input here will appear at the 'L BUS' jumper terminal for both of the ST55.2's jumper modules.

NO VOL - If volume control is desired only from the source, or if outputs are being combined to obtain higher power, the jumper plug should be installed at the 'NO VOL' location.

USE VOL - If volume control is desired at the amplifier, beyond that provided at the source, a shorting plug is installed at the 'USE VOL' location. The 'USE VOL' setting **SHOULD NOT** be used when channels are bridged or combined.

Invert Jumper module - This is a single jumper module that is set apart, up and to the right from the channel jumper modules on the circuit board. It provides a special function, when the jumper is set on the '-L' pins, the left bus signal feeding the left channel will be inverted.

Note: A jumper MUST be installed at L BUS, R BUS, or L+R BUS, AND a jumper MUST be installed at NO VOL or USE VOL for the amplifier to operate.

MONO APPLICATION (MEDIUM CURRENT)

The ST55.2's two output channels may be paralleled (mono) to combine the left and right channels output current. This feature allows the amplifier to double its apparent output current. To use, place the source group jumper for both channels on the 'L BUS' jumper terminal. Place the volume group jumper for both channels on the 'NO VOL' jumper terminal.

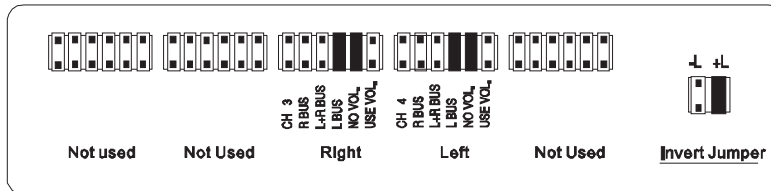

The speaker output terminals on the ST55.2's rear panel must be paralleled in order to complete the setup. Simply connect the (+) terminals for both channels together using a jumper wire (not supplied with the amplifier). Finally, connect the speaker cables from the left channels (+) and (-) terminals to the speakers. Input your source signal into the left channel input. The instructions show the use of the left channel. You may also use the right channel if you desire, just follow the above instructions using the right channel. You may also use the L+R BUS to send a mono signal out of the amplifier derived from the left and right channels. See the Bus Inputs below:

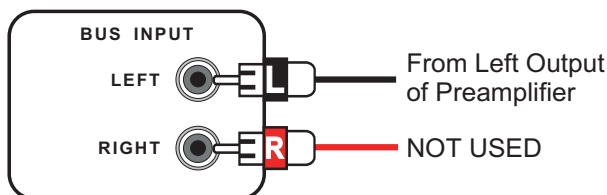
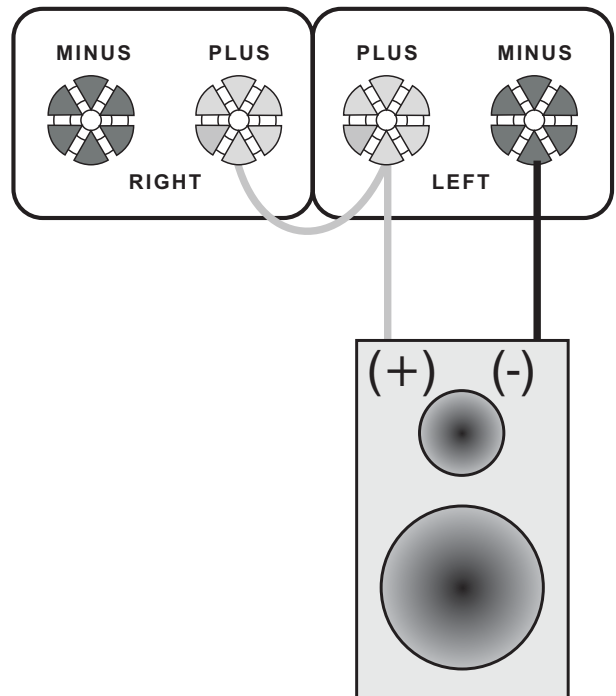

BRIDGED APPLICATION (HIGH VOLTAGE)

The ST55.2 may be bridged to drive a high impedance speaker. To use, place the source group jumper for both channels on the 'L BUS' jumper terminal. Place the volume group jumper for both channels on the 'NO VOL' jumper terminal. Place the jumper module on the '-L' terminal.

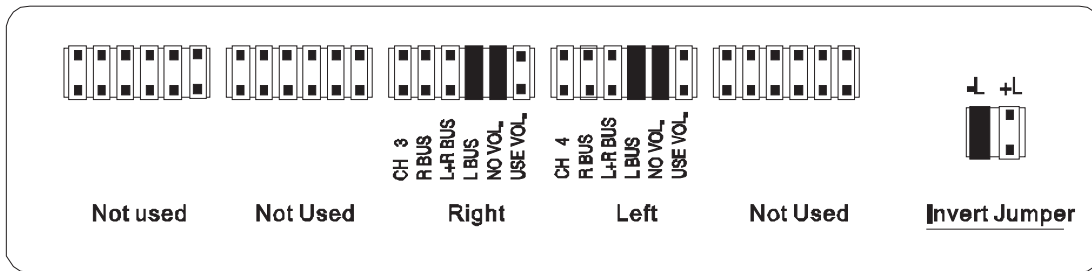

Finally, connect the speakers (+) to the right channels (+) terminal and the speakers (-) to the left channels (+) terminal. Input your source signal into the left channel input (*only the left channel may be used for bridging*).

Note: The default position for this jumper plug is set to the '+L' terminal. The jumper plug must be installed at this location at all times when not using the '-L' (invert) function.

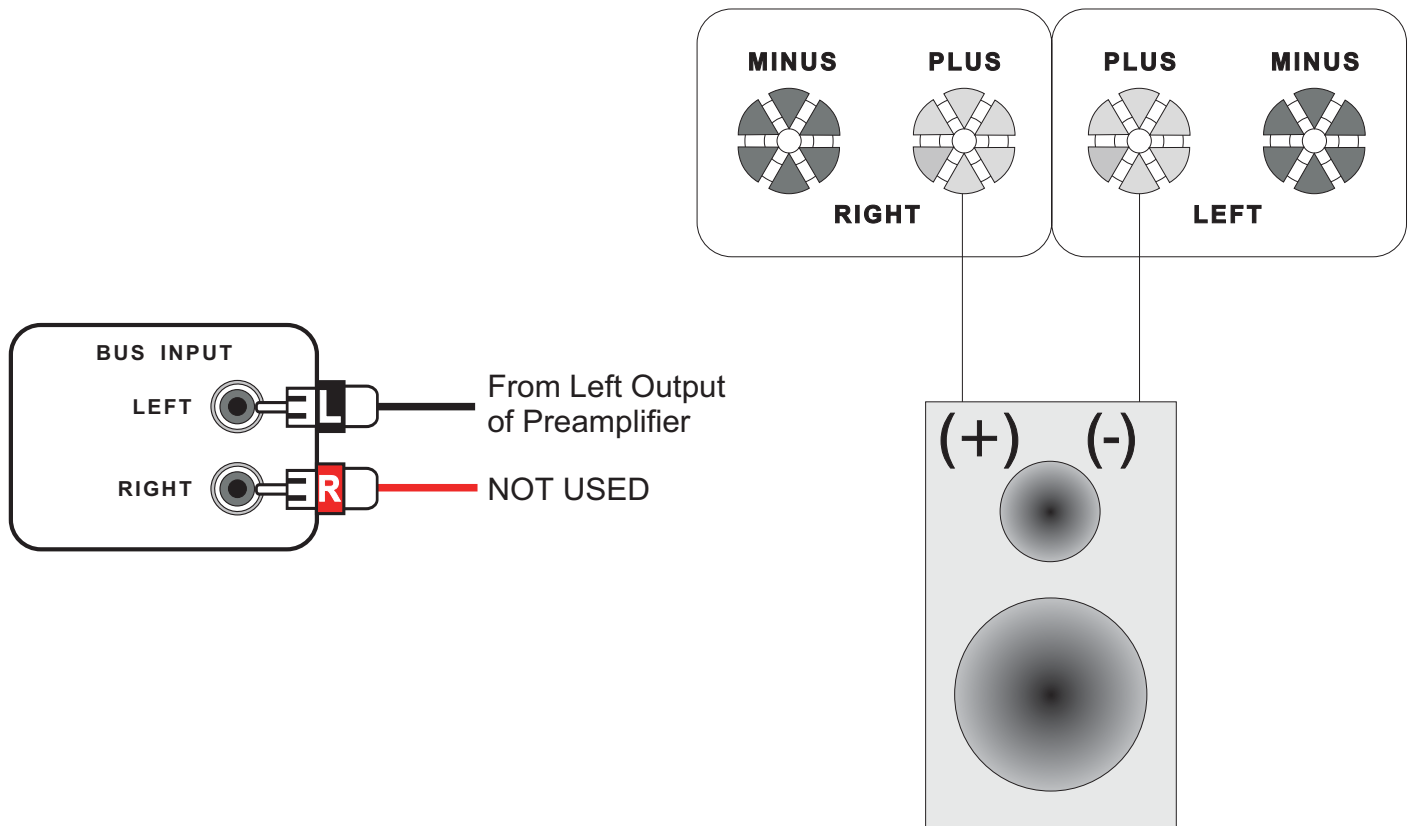

SYSTEM INSTALLATION

There will most likely be a number of cables involved in the installation of your home entertainment system. Preplanning is essential in order to maximize system efficiency. We recommend the following as a means of helping you reach that goal.

- Make a diagram of your proposed system by laying out the relative location of each component in the system. Then lay out the proposed cable runs between them. Number each cable and record its length on the diagram for future use.
- Cable runs are critical in that they must be kept away from the sources of power radiation (amplifiers, power cords, heaters, appliances, etc.). For safety reasons, they should also be kept out of traffic areas.
- The process of optimizing the system will include the type of cable, the length of the run, and the obstructions it must deal with along its run. Your dealer can advise you on the products available and their relative merits. If building custom length audio cable is not your strength, your dealer should be able to help you with that as well.
- When possible, use a separate AC power line for the amplifier, one that is not shared by any other household component. **THIS IS VERY IMPORTANT!!!**

Tip: Take a piece of string (longer than the longest cable run) and mark it at each foot of length. Then do a mock cable run using the string, dressing it neatly along the way. Count the divisions to the next full foot, and add one foot to all for some movement of the components. This will provide you with ideal cable length.

MAKING THE CONNECTION

- Before doing anything, insure that the power switch on the amplifier's front panel is in the 'off' position.
- Again, it is recommended that you locate a separate AC power outlet for the amplifier, one that is **not** shared by any other audio component in the system or any other household component. This will eliminate the possibility of the amplifier 'modulating' the power being supplied to the component and compromising the signal originating from that component.
- Locate the AC power cord provided with the amplifier and plug it into the power input receptacle in the rear panel. **Do not connect it to the AC power source yet!**
- Connect the audio cable from your preamplifier's output to the corresponding input connector on the amplifier.
- Connect the wire from your speakers to the appropriate outputs on the amplifier. It is absolutely essential that you observe correct polarity in all these connections.

Example: If you connect your left output of your preamplifier to channel 4 input on the amplifier, remember to connect your left speaker wires to channel 4's outputs. Always observe polarity when connecting speakers, connect amplifiers (+) to the speakers (+) and amplifiers (-) to speakers (-).

- Double-check all connections.
- Connect a playback unit (CD, DVD, VLD, Tuner, etc.) to the preamplifier. Turn on the preamplifier, turn the volume on the preamplifier to a minimum level, and then turn on the amplifier (in that order). Set the source on the preamplifier to the playback unit you've just connected. Turn the volume up slowly and listen for music from all channels. If this is not the case, and you don't hear any sound, double-check your installation.
- Should you encounter any problem that cannot be traced to the source or the material being played, consult the "TROUBLESHOOTING" section on page 10.

Note: When turning equipment 'off', the amplifier should always be turned off **first**, then the preamplifier. **Before turning anything on, insure the preamplifier is at a low volume level.**

TROUBLESHOOTING

PROBLEM	POSSIBLE CAUSE	POSSIBLE SOLUTION
No sound ('on' LED not illuminated)	<ol style="list-style-type: none"> 1. Power cord not plugged in. 2. Power off at AC source. 3. AC power inlet fuse blown or faulty 4. Control Input not activated. 	<ol style="list-style-type: none"> 1. Reconnect power cord. 2. Check AC switch or fuse 3. Check for shorts or overloading 4. Supply Control IN with a 5-24 Volt AC or DC supply (Page 7)
No sound on some or all selected channels ('on' LED illuminated)	<ol style="list-style-type: none"> 1. Speaker leads loose or faulty 2. Line stage to amp cables loose or faulty 3. Source to line stage cables loose or faulty 4. Line stage or source not correctly selected 5. Speaker fuse blown 	<ol style="list-style-type: none"> 1. Tighten, repair or replace cable 2. Tighten, repair or replace cable 3. Tighten, repair or replace cable 4. Check all switch settings 5. Check all speaker fuses
Sound lacks direction, bass weak	<ol style="list-style-type: none"> 1. Speakers connected out of phase 	<ol style="list-style-type: none"> 1. Check all connections making sure that cables are connected (+) to (+) and (-) to (-)
Loud hum or buzz on one or more channels	<ol style="list-style-type: none"> 1. Poor ground connection in inter-connect cables 	<ol style="list-style-type: none"> 1. Check all connectors and repair as necessary
Channel sounds distorted and low output	<ol style="list-style-type: none"> 1. Blown rail fuse 	<ol style="list-style-type: none"> 1. Replace blown rail fuse inside amplifier.

* **Note:** If unit continues to blow power inlet fuses, **DO NOT USE A HIGHER RATED FUSE**, please contact customer service to have the unit serviced.

CARE AND CLEANING

Under normal use, the amplifier will not require any special care. Over time you may wish to clean the exterior of the unit by wiping it with a damp cloth to remove any dirt or dust that accumulates on it. Unplug the amplifier and be sure that it has completely powered down before you apply any damp cloth. Do not let any liquid enter the amplifier through the vents in the top cover. **REMEMBER, LIQUIDS CONDUCT ELECTRICITY!!!** You may clean the connectors on the back panel with isopropyl alcohol annually.

SPECIFICATIONS

Power Rating: 8 ohms 4 ohms	55 watts @ 1 kHz Not recommended
THD (S+N)	0.09 % @ 1 kHz
Frequency response	5 Hz – 45 kHz
Input sensitivity	0.77 Volts
Input impedance	33.2 k ohms
Damping factor	100
Current (peak to peak)	20 Amps
Slew rate	14 V / μ sec
Dynamic headroom	1.4 dB
S/N (A-weighted)	95 dB
Voltage gain	28
Line voltage	120/220/240 VAC switchable
Dimensions (O.A.)	17"(w) X 12"(d) X 3.75"(h)
Weight	23 lbs. max.
Power consumption	210 watts max 2.3 Amps max current draw 15 watts @ no input
Replacement fuses	Line - 8 Amp/250 Volt Slow Blow Rails - 4 Amp/250 Volt T-Lag

LIMITED WARRANTY

B & K Components Ltd., referred to herein as B & K, warrants your B & K equipment against all defects in material and workmanship for a period of five years from the date of purchase. This warranty applies only to the original purchaser and only to equipment in normal residential use and service. Defective equipment must be returned to B & K, prepaid, accompanied by proof of purchase and sufficient payment to cover the cost of return shipping and handling, and will be repaired or replaced at the discretion of B & K whose decision as to the method of reparation will be final.

This warranty shall not apply to any equipment which is found to have been improperly installed, incorrectly fused, misused, abused, or subjected to harmful elements, used in any way not in accordance with instructions supplied with the unit, or to have been modified, repaired or altered in any way without the expressed, written consent of B&K. This warranty does not apply to the cabinet or appearance items such as the faceplate or control buttons, nor does it cover any expenses incurred in shipping the unit to and from the manufacturer's service depot.

This warranty on B & K Components, Ltd. products is NOT VALID if the products have been purchased from an unauthorized dealer or an E-tailer or if the original factory serial number has been removed, defaced or replaced in any way. B & K Components, Ltd. sells its products through authorized dealers in order to insure that consumers obtain proper dealer service and support. Buying from an authorized B & K Components, Ltd. dealer insures that you have a FACTORY WARRANTY on your B & K Components, Ltd. product. If you have any questions concerning your Factory Warranty call B & K Components, Ltd. at 716-656-0023.

Upgradability: B & K is one the first manufacturers in the audio/video industry to consistently offer software and hardware upgrades to its processing of audio signals. Through upgrades B & K delivers exceptional value to its customers. But what is "Upgradability"? Upgradability is not a guarantee; we define it as a philosophy of designing and manufacturing products so that as audio technology evolves, B & K can provide enhancements and improvements to its products that are economically viable.

THE EXPRESS FACTORY WARRANTY HEREIN CONTAINED IS IN LIEU OF ANY AND ALL OTHER WARRANTIES, EXPRESSED OR IMPLIED, INCLUDING ANY WARRANTY OF MERCHANTABILITY, UPGRADABILITY OR OF FITNESS FOR ANY PARTICULAR PURPOSE. B&K COMPONENTS, LTD. SHALL NOT UNDER ANY CIRCUMSTANCES BE LIABLE FOR DAMAGES, INCLUDING SPECIAL, INCIDENTAL, EXEMPLARY, PUNITIVE OR CONSEQUENTIAL DAMAGES ARISING OUT OF OR IN CONNECTION WITH THE PURCHASE, USE OR PERFORMANCE OF ANY B&K PRODUCT.

This warranty gives you specific legal rights. You may also have other rights which vary from State to State. Some States do not allow the exclusion or limitation of incidental or consequential damages and the foregoing exclusions may not apply to you.

No agent, representative, dealer or employee of B&K has the authority to increase or alter the obligations or terms of this warranty.

RETURNING EQUIPMENT

No equipment may be returned to B&K Components Ltd. without a RETURN AUTHORIZATION (RA). Should you find it necessary to return equipment to B&K, for any reason, a RETURN AUTHORIZATION (RA) number must be issued by B&K in respect of the equipment being returned. You may request an RA number by calling B&K at the numbers below. We will need the following information to issue your RA number. Please have it ready before you call.

1. Your name, address, and phone number.
2. The model and serial number of the equipment being returned.
3. A description of the problem being experienced.
4. Your sales receipt.

Your call will be referred to a Technical Service Representative who will work with you to resolve the problem. If it is determined that the unit must be returned for repair, an RA number will be issued.

B&K Components, Ltd., 2100 Old Union Road, Buffalo New York 14227-2725
Phone 1-800-543-5252 or (716) 656-0026, **Fax** (716) 656-1291
E-mail: info@bkcomp.com **Web:** www.bkcomp.com

WWW.BKCOMP.COM

B&K Components, Ltd.
2100 Old Union Road
Buffalo, New York 14227
Phone: 716 – 656 - 0026